

PARTS LIST				
ITEM	QTY	PART NUMBER	DESCRIPTION	
1	4	V20017	3/8-16 X 4" HHCS	
2	4	V20018	3/8" LOCKWASHER	
3	4	V20019	3/8" HEX NUT	
4	1	V20020	2" handle Bolt	
5	1	V20021	Handle Washer	
6	1	V20151M	VALVE STEM W/ BEARING	
7	1	V20153	HANDLE	
8	1	V20159	2" STEM BUSHING	
9	1	V20163	AS568A -116 O-RING, FKM, BROWN	
10	1	V20254	2" VALVE BODY	
11	1	V20255A	2" Valve Ball	
12	2	V20257B	1-1/2" BSPC ENDPLATE, MACHINED	
13	2	V20258A	2" Valve Seat	
14	2	V20264	AS568A -151 O-RING, FKM, BROWN	
15	1	VL1001	PRESSURE LABEL (N/S)	

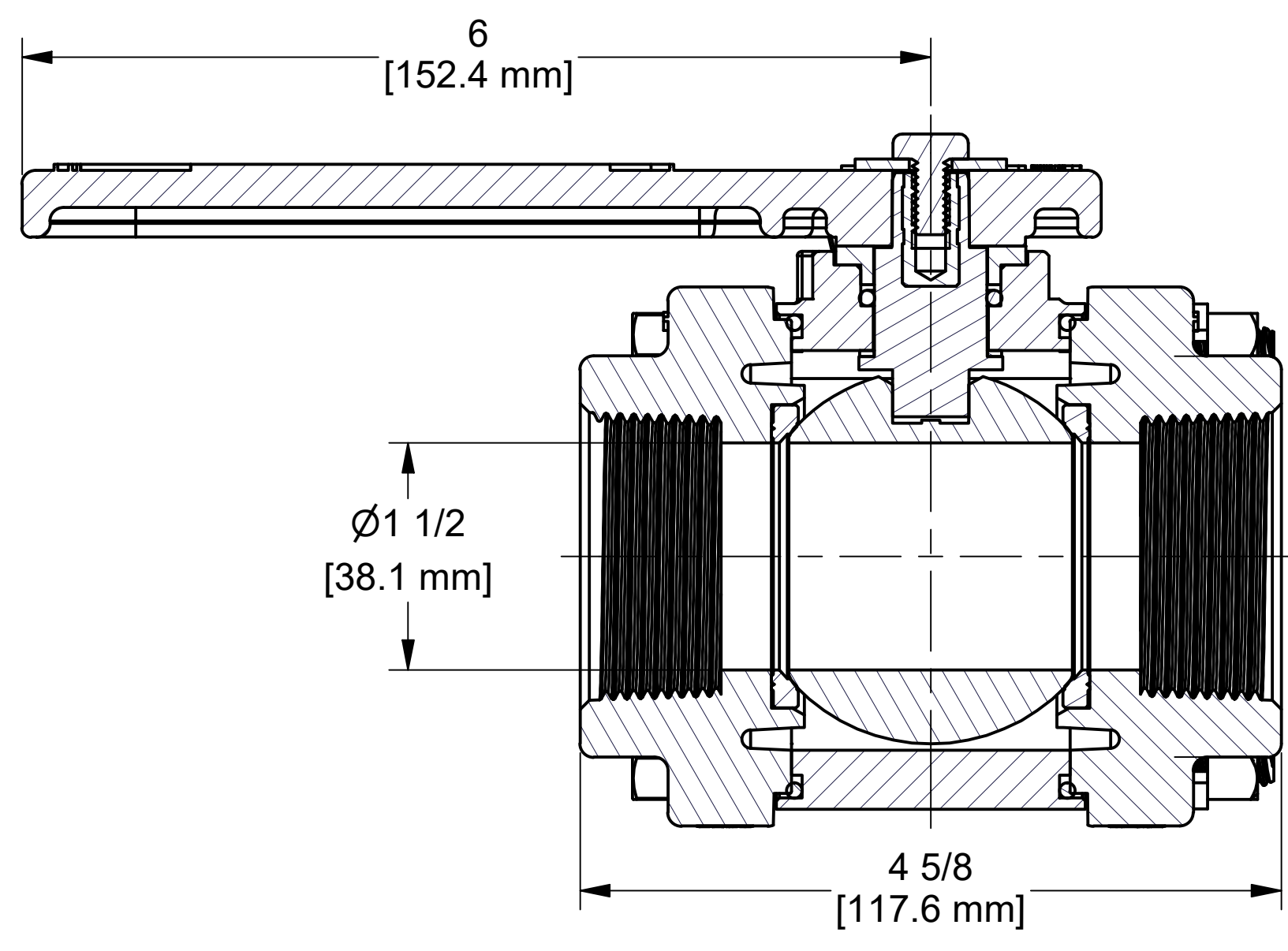

SECTION B-B
SCALE 1 : 1

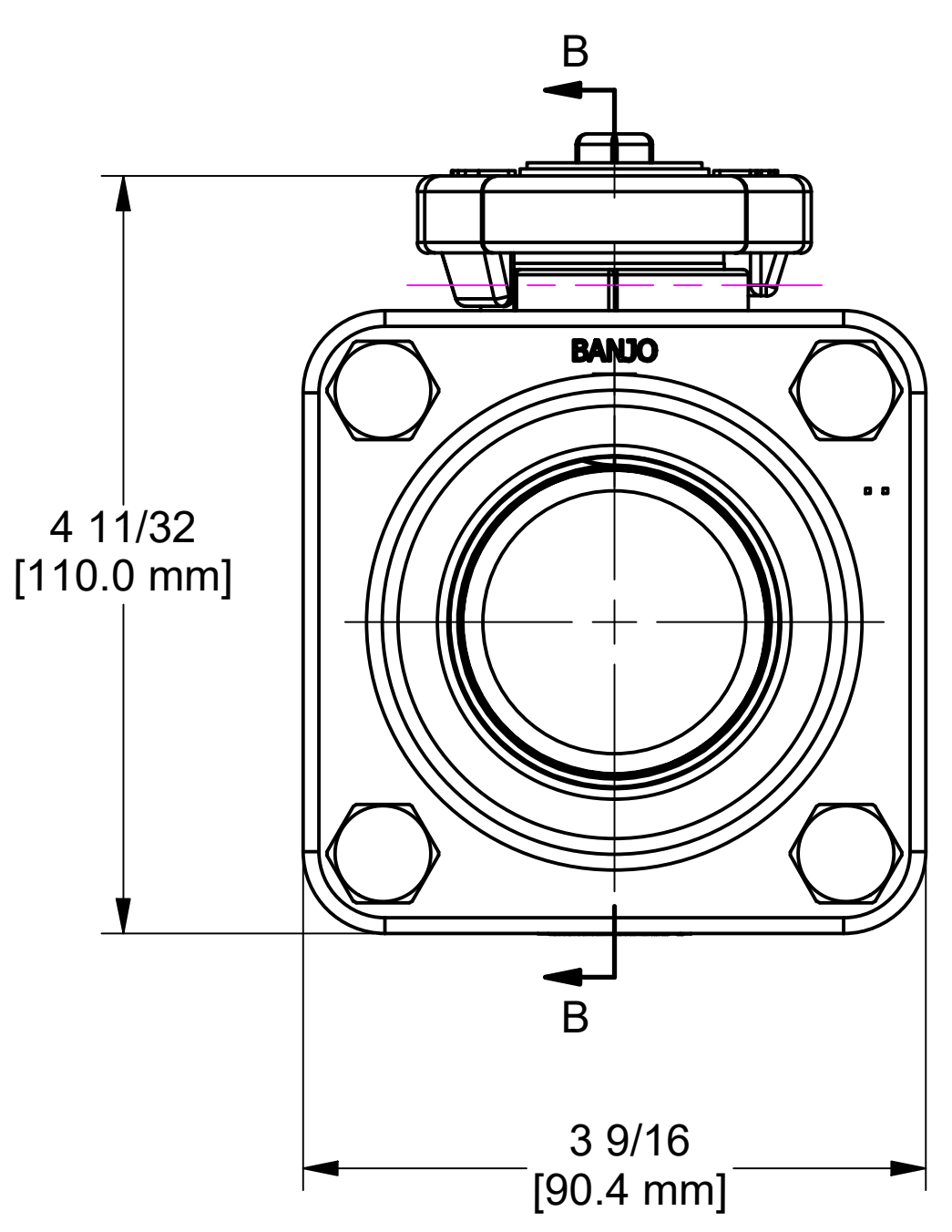
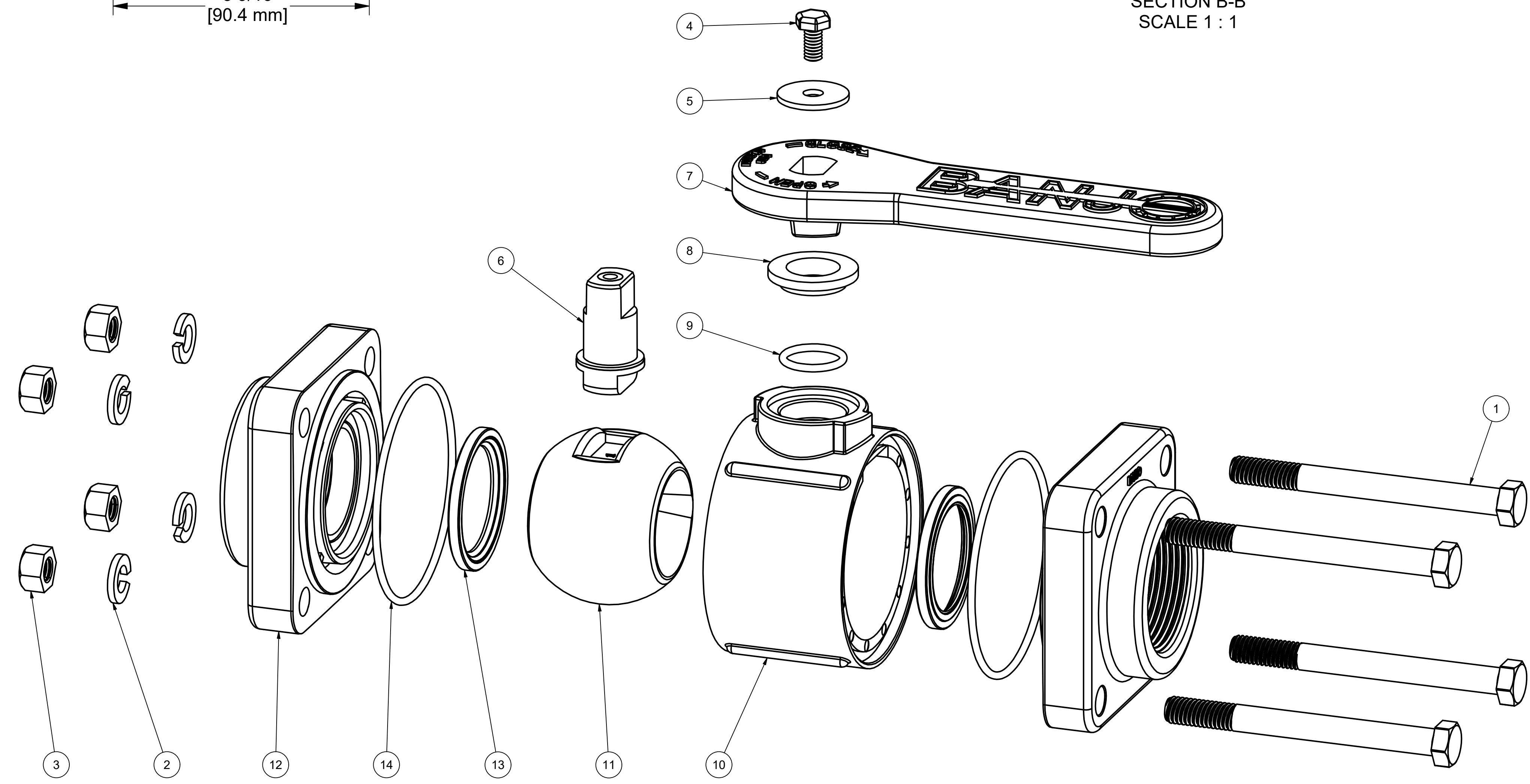

THIS DRAWING AND ALL INFORMATION CONTAINED THEREON ARE THE EXCLUSIVE PROPERTY OF BANJO CORPORATION.

UNLESS SPECIFICALLY NOTED, THIS DRAWING AND ITEMS SHOWN ON THIS DRAWING ARE SUBJECT TO CHANGE AT ANY TIME.

BANJO CORPORATION
150 BANJO DRIVE, CRAWFORDSVILLE, IN 47933
WEB SITE: WWW.BANJO.CORP.COM
E-MAIL: BANJOSALES@IDEXCORP.COM

DESCRIPTION
1-1/2" VALVE BSP

PART NUMBER
V150B